

FRONT VIEW

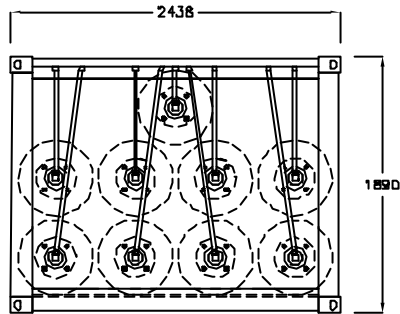

REAR VIEW

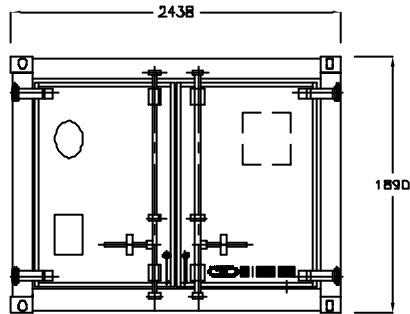

REAR VIEW

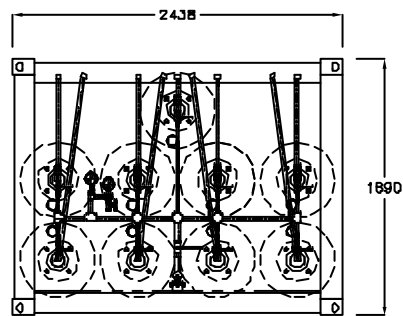

B-B SECTION

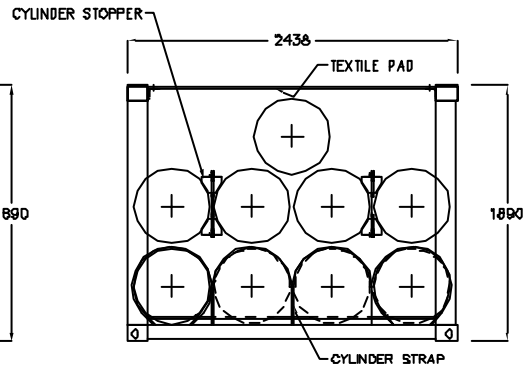

NOTE

1. PRODUCT : CNG
2. TUBE :
 - 9 DOT 3AAX & EB009-257D(177bar), OD 22"(558.8mm) x 35"-10"(10930mm)L x D.870"(14.6mm)WALL
3. SKID : ACCORDING TO ISO 668
4. WEIGHT SPECIFICATION
 - TUBES : 22,275 kg
 - SKID : 3,140 kg
 - PRODUCT : 3,410 kg
 - AGCY : 4.00 kg
 - GROSS : 29,230 kg

APPROVED	J. S. SHIM	STORAGE SKID for CNG GAS 22"OD x 35"-10"L x 9 TUBES			
CHECKED					
CHECKED	Jangsung-Jeon				
DRAWN	Jangsung-Jeon				
	MODEL NO.	DATE	DWG NO.	SHEET	REV.
	TT09-2285CNG	05.07.07	182-303-370	1/1	D
		SCALE			
		1/33			